

PARTS LIST			
ITEM	QTY	PART NUMBER	DESCRIPTION
1	1	MainStructure	
2	1	Door1Assembly	
3	1	Door2Assembly	
4	1	CenterHinge	

UNLESS NOTED OTHERWISE DIM ARE IN INCHES. TOL ARE: .00 ±.01 .00 ±.005 .00 ±.02 ANGULAR ±.05	SIGNATURES DR Zach Tullier ENG CH APP QE MATL STRESS AUTH	DATE	NATIONAL AERONAUTICS AND SPACE ADMINISTRATION LYNDON B. JOHNSON SPACE CENTER HOUSTON, TEXAS		
SURFACE FINISH IN MICRONS UNLESS NOTED OTHERWISE			PROJECT		
NEXT ASSY			SIZE	CAGE CODE	DWG NO
DWG FILENAME			D		
DRAWING TYPE			SCALE	ORG	FM TAO2MAY04 SHEET 1 OF 9

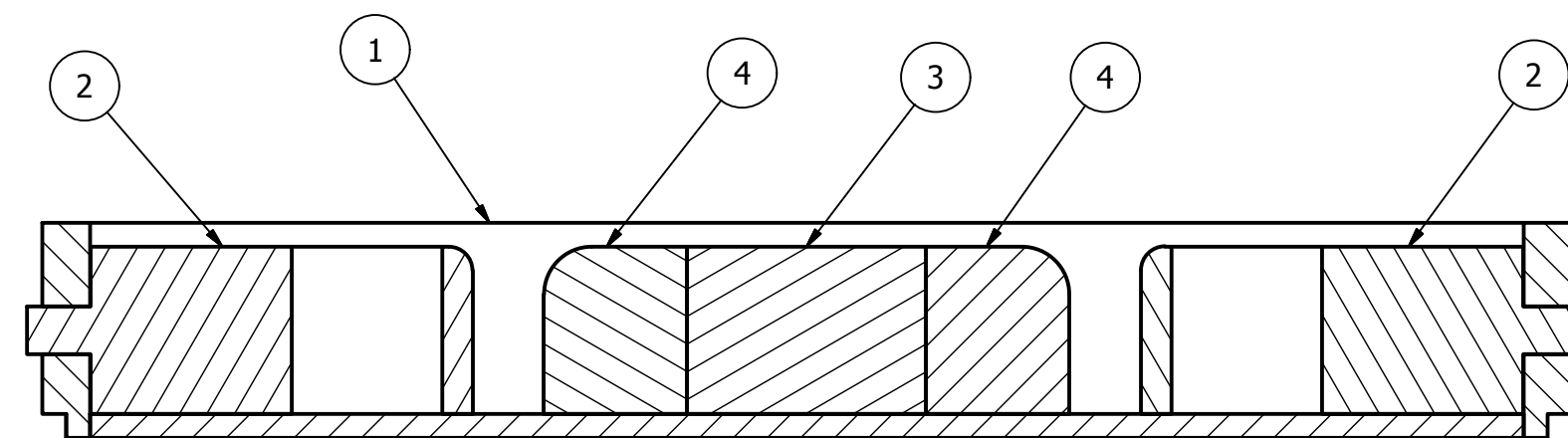
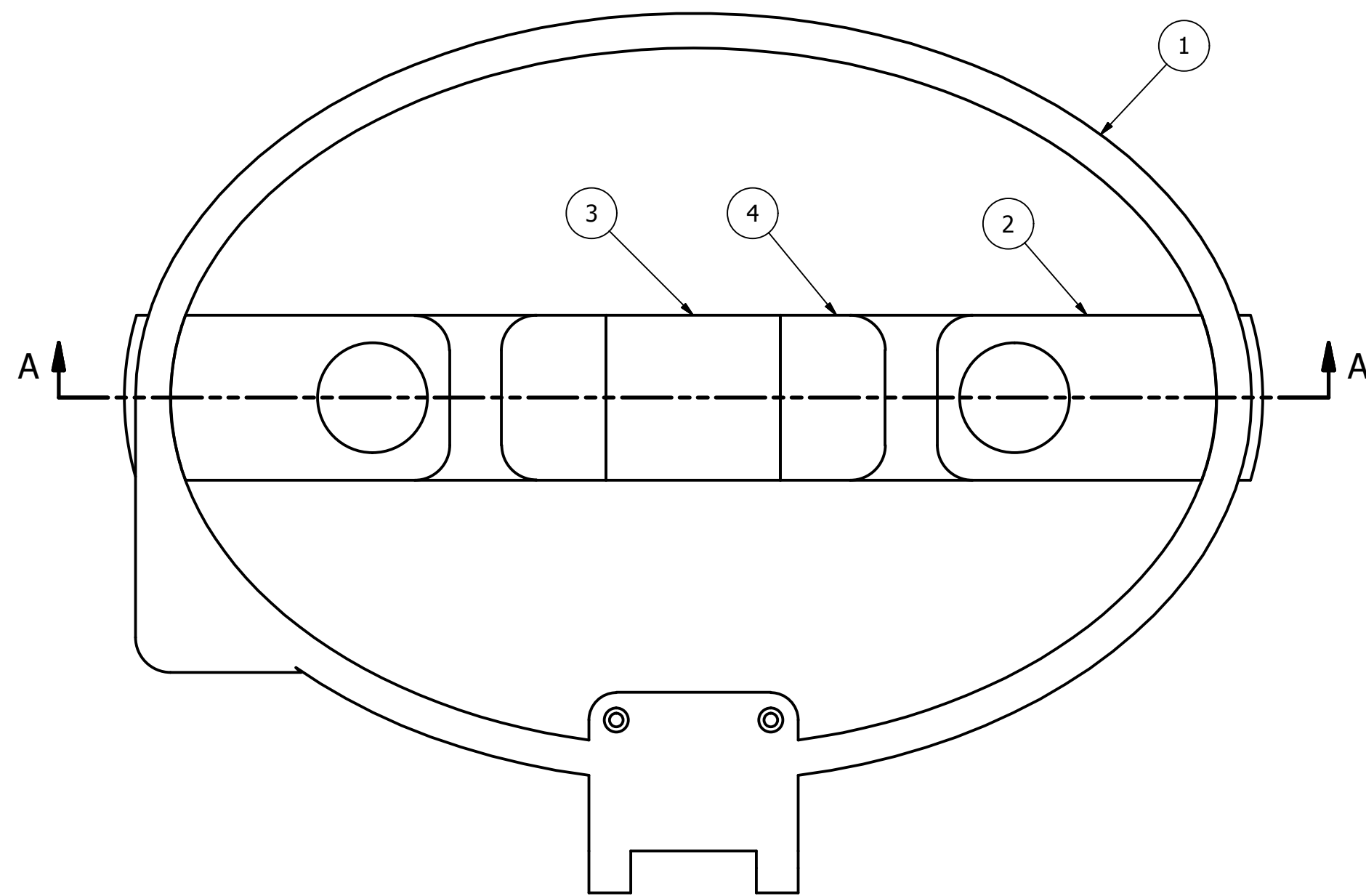

PARTS LIST			
ITEM	QTY	PART NUMBER	DESCRIPTION
1	1	Door1	
2	2	FingerGrip	
3	1	LockOpen	
4	2	LockOpenRails	

UNLESS NOTED OTHERWISE DIM ARE IN INCHES. TOL ARE: .00 ±.01 .00 ±.005 .00 ±.02 ANGULAR ±.05	SIGNATURES	DATE	NATIONAL AERONAUTICS AND SPACE ADMINISTRATION		
	DR Zach Tullier		LYNDON B. JOHNSON SPACE CENTER HOUSTON, TEXAS		
SURFACE FINISH IN MICRONS UNLESS NOTED OTHERWISE	ENG				
	CH				
NEXT ASSY	APP				
	QE				
DWG FILENAME	MATL		PROJECT		
DRAWING TYPE	STRESS		SIZE	CAGE CODE	DWG NO
	AUTH		D		REV
			SCALE	ORG	FM TA02MAY04 SHEET 2 OF 9

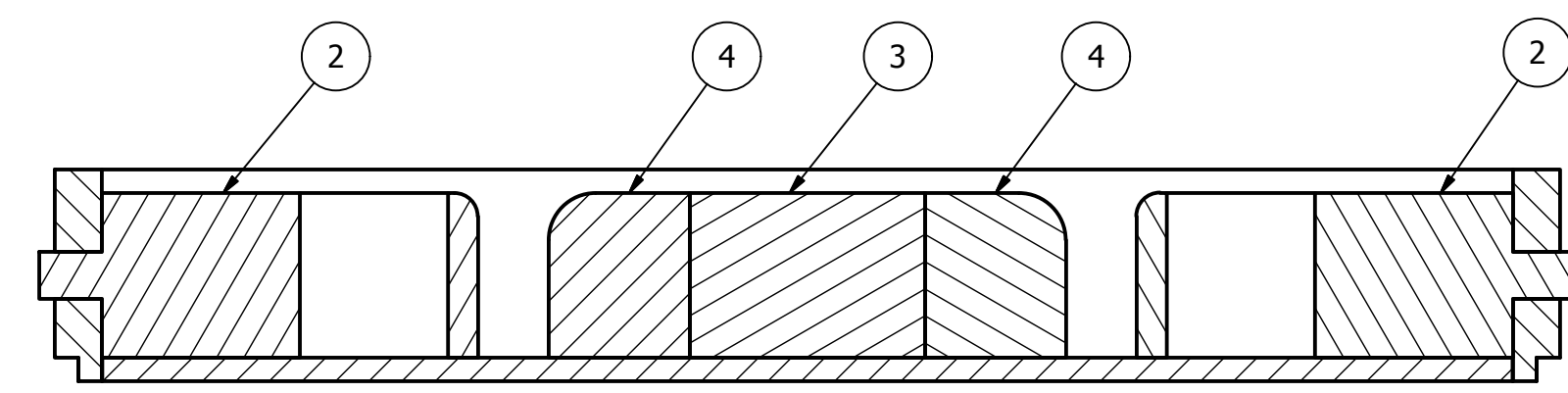
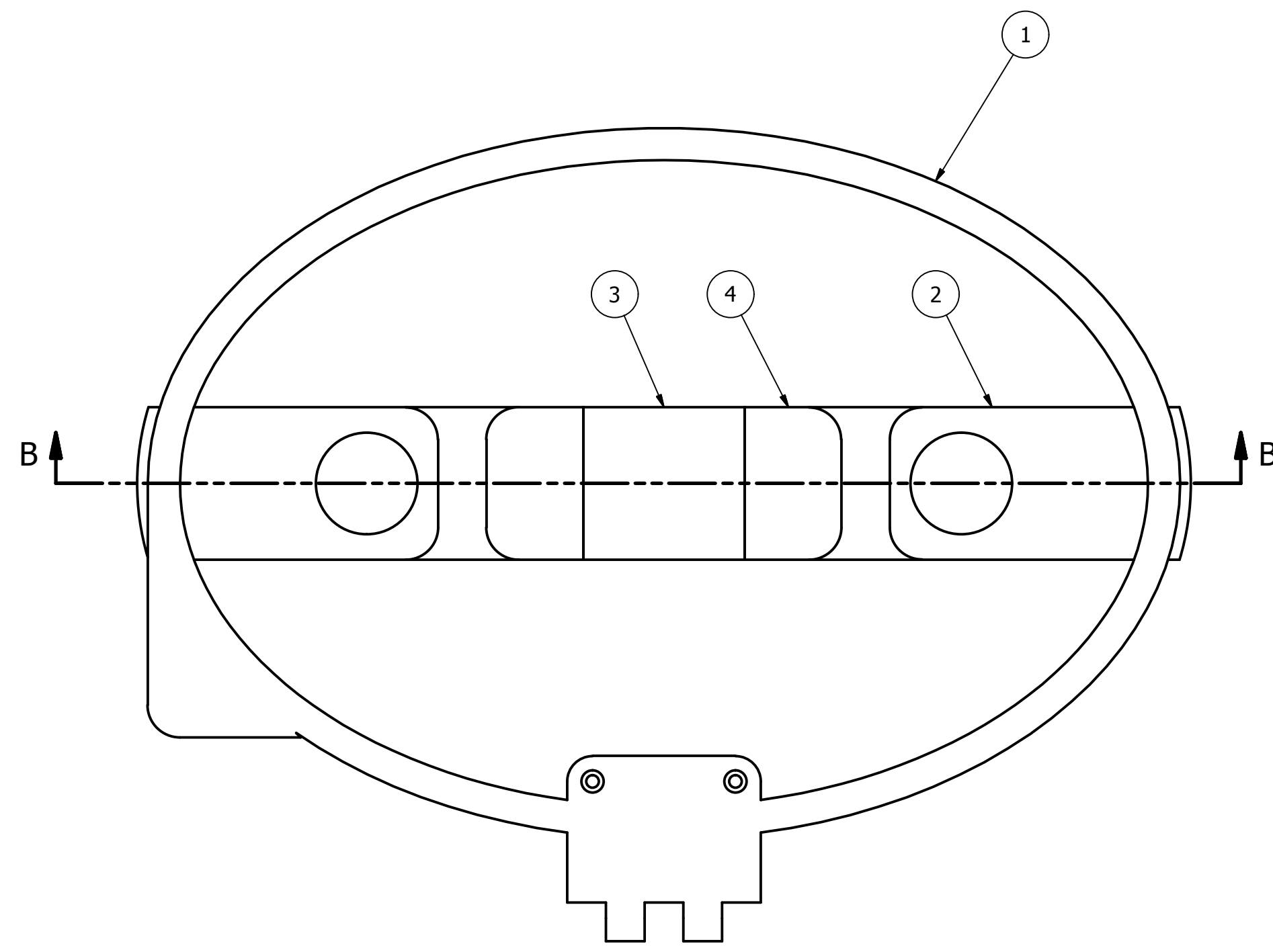

SECTION B-B
SCALE 1 : 1

PARTS LIST			
ITEM	QTY	PART NUMBER	DESCRIPTION
1	1	Door2	
2	2	FingerGrip	
3	1	LockOpen	
4	2	LockOpenRails	

UNLESS NOTED OTHERWISE DIMS ARE IN INCHES TOL ARE: 0 ±.1 .00 ±.005 .00 ±.02 ANGULAR ±.05	SIGNATURES	DATE	NATIONAL AERONAUTICS AND SPACE ADMINISTRATION		
	DR Zach Tullier		LYNDON B. JOHNSON SPACE CENTER HOUSTON, TEXAS		
SURFACE FINISH IN MICROINCHES RMS UNLESS NOTED OTHERWISE	ENG				
	CH				
NEXT ASSY	APP				
	QE				
DWG FILENAME	MATL		PROJECT		
DRAWING TYPE	STRESS		SIZE	CAGE CODE	DWG NO
	AUTH		D		
			SCALE	ORG	FM TAO2MAY04 SHEET 3 OF 9

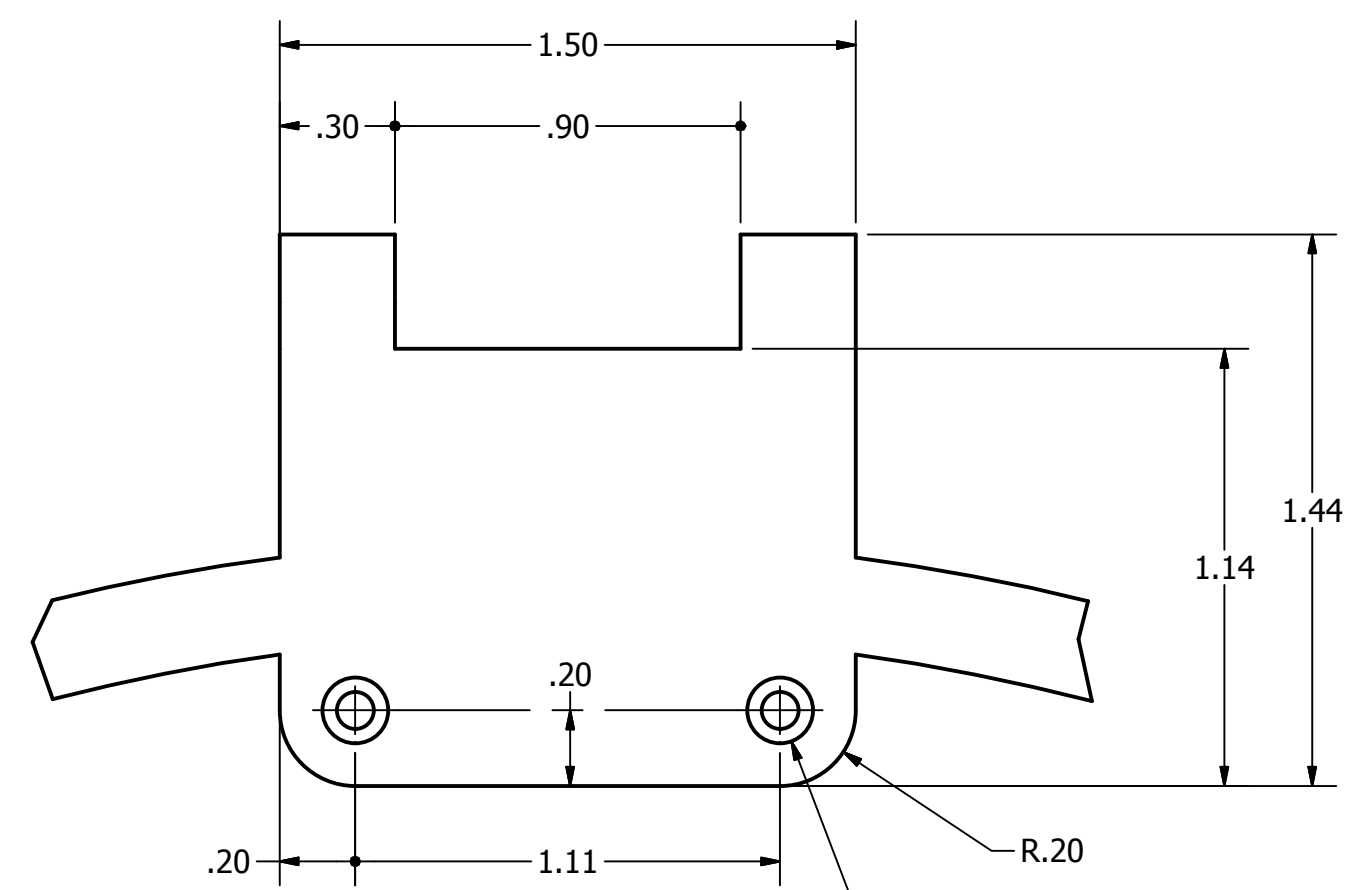
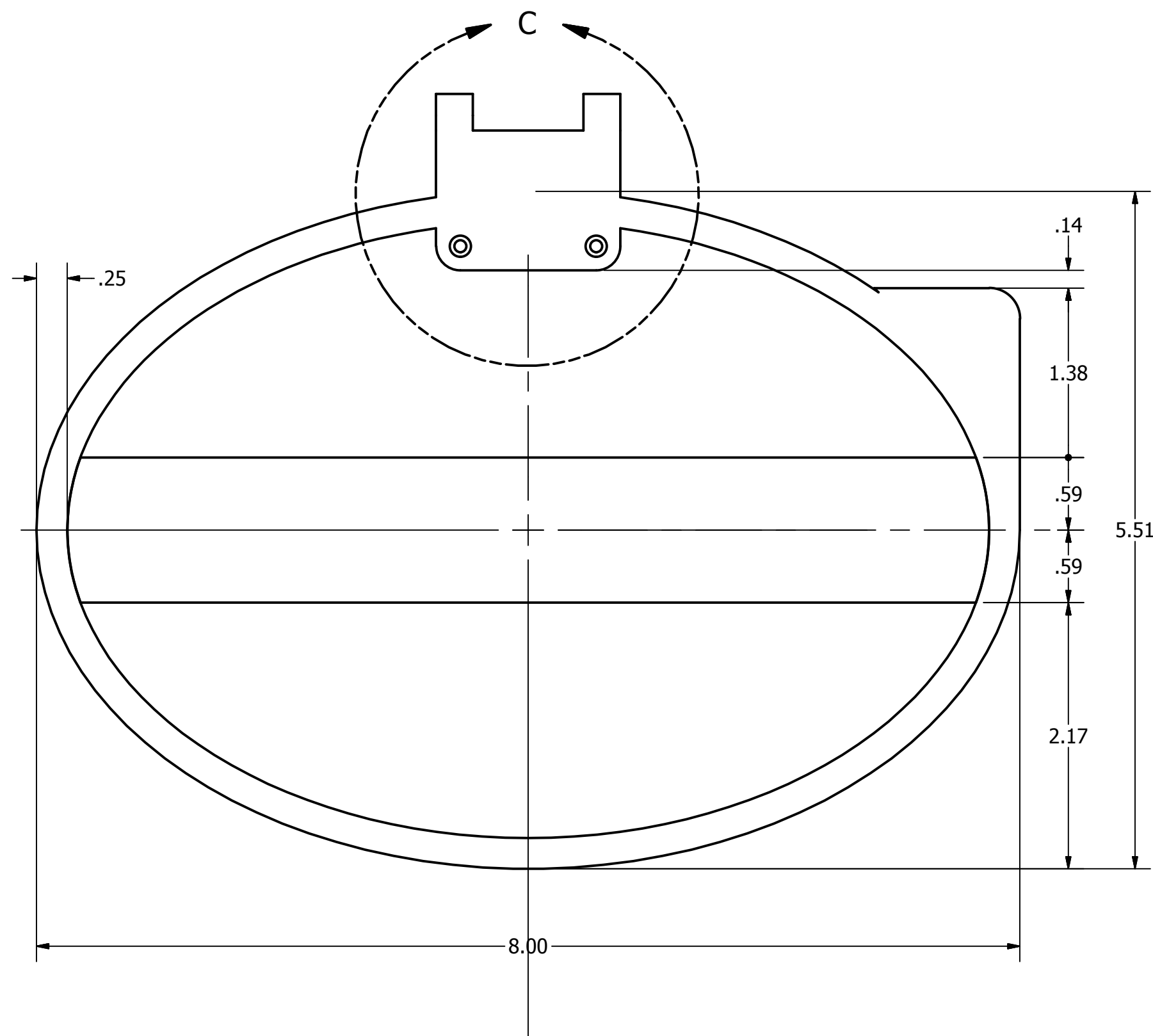

DETAIL C
SCALE 2 : 1

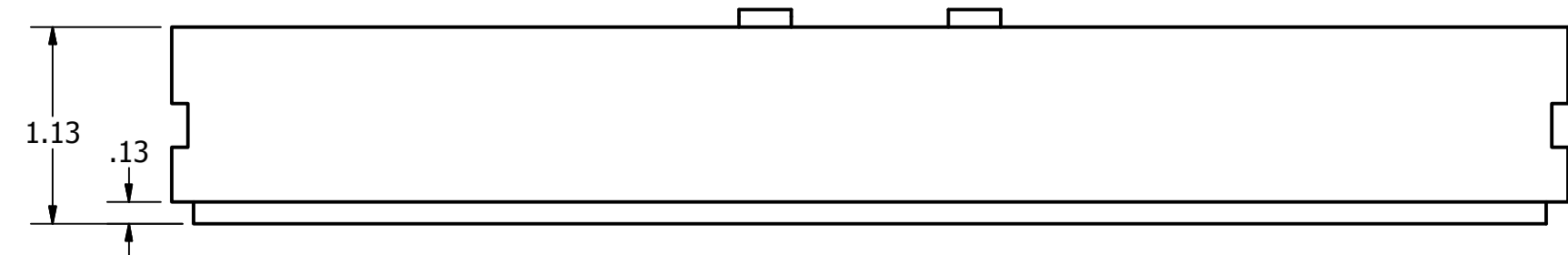
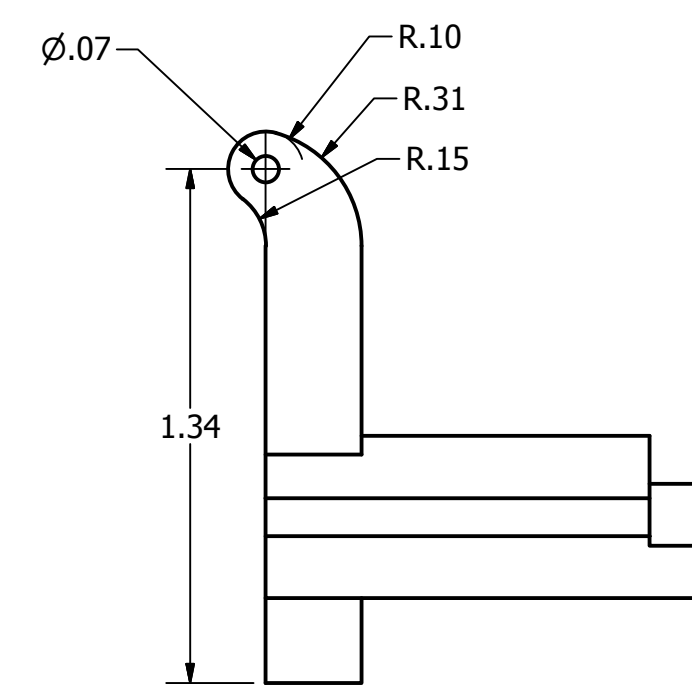

SIZE D	CAGE CODE 21356	DWG NO ?	REV
SCALE 2	ORG OZ4	FMT F02MAY04	SHEET 4 OF 9

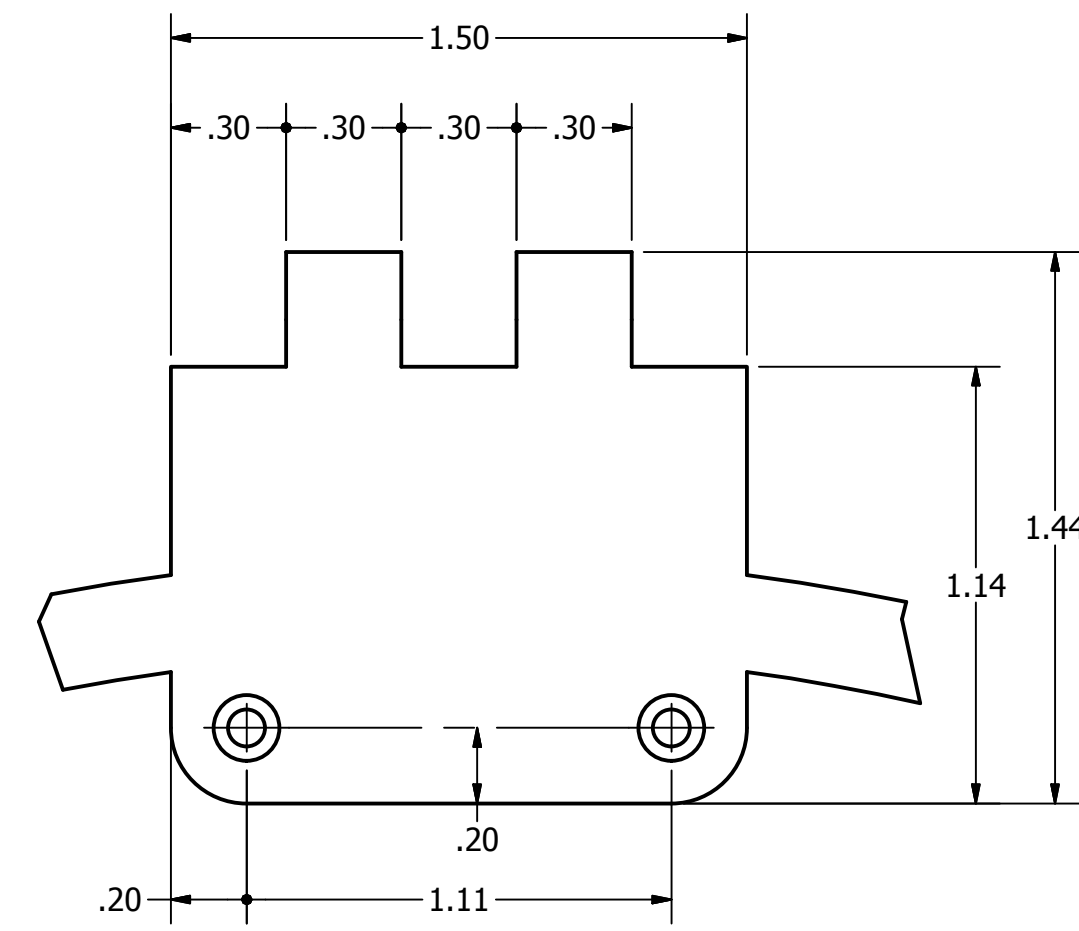
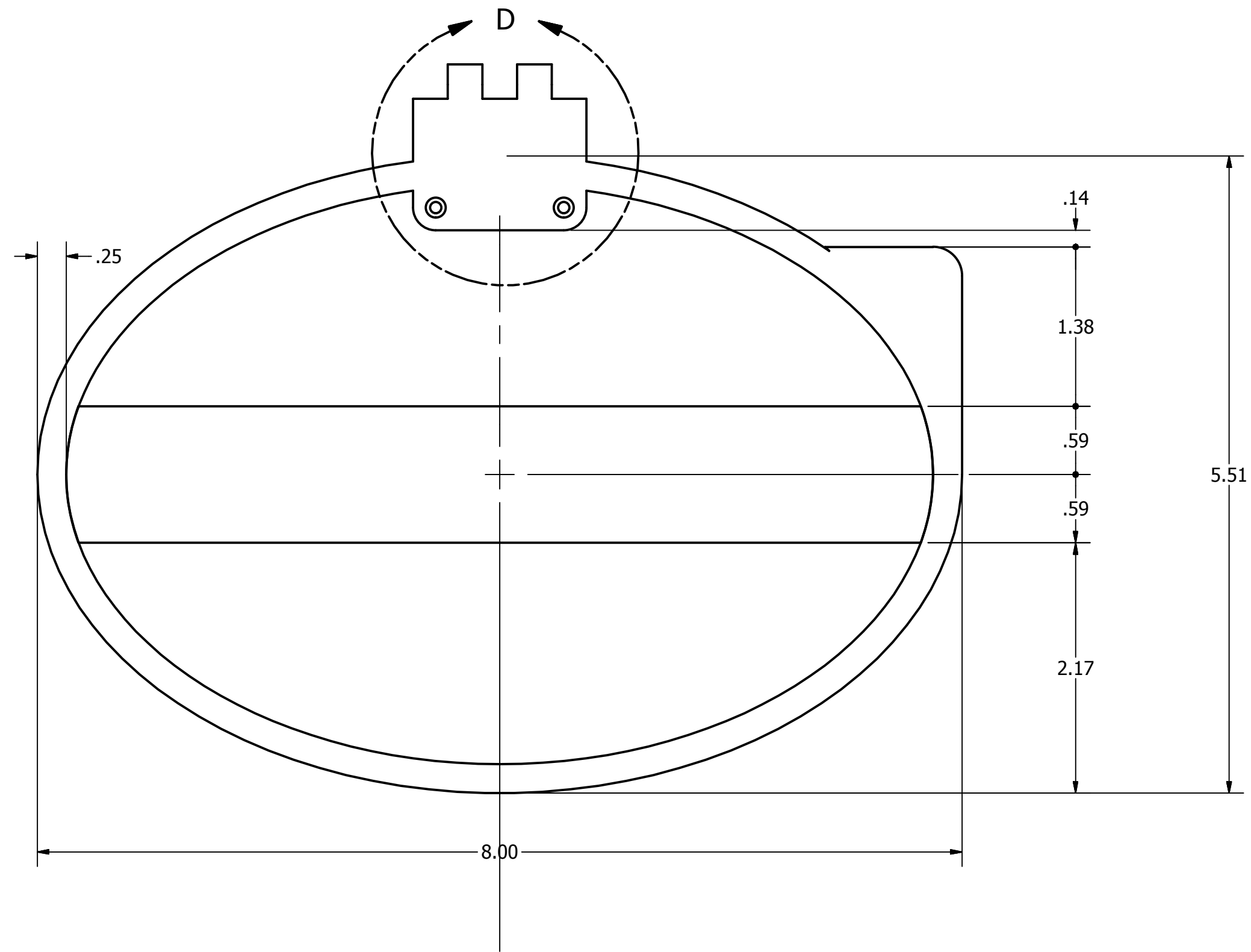

DETAIL D
SCALE 2 : 1

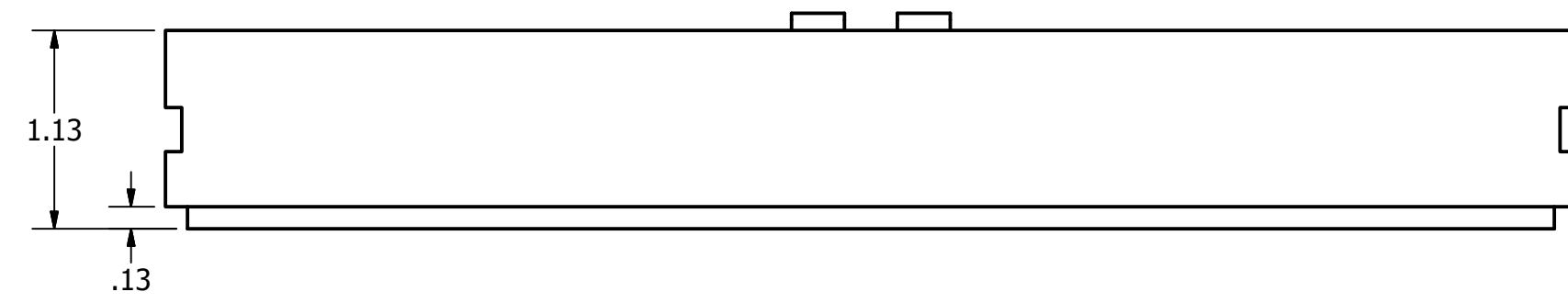
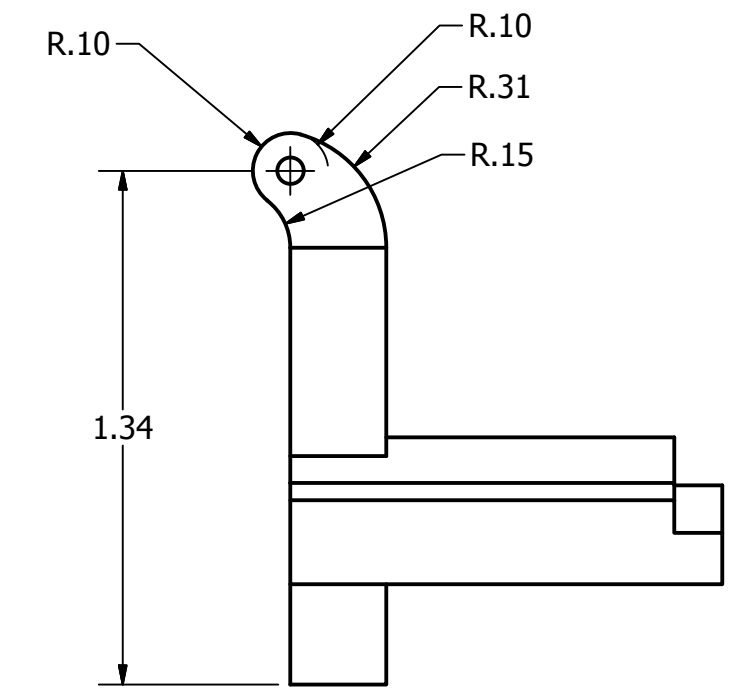

SIZE D	CAGE CODE 21356	DWG NO ?	REV
SCALE 2	ORG OZ4	FMT P02MAY04	SHEET 5 OF 9

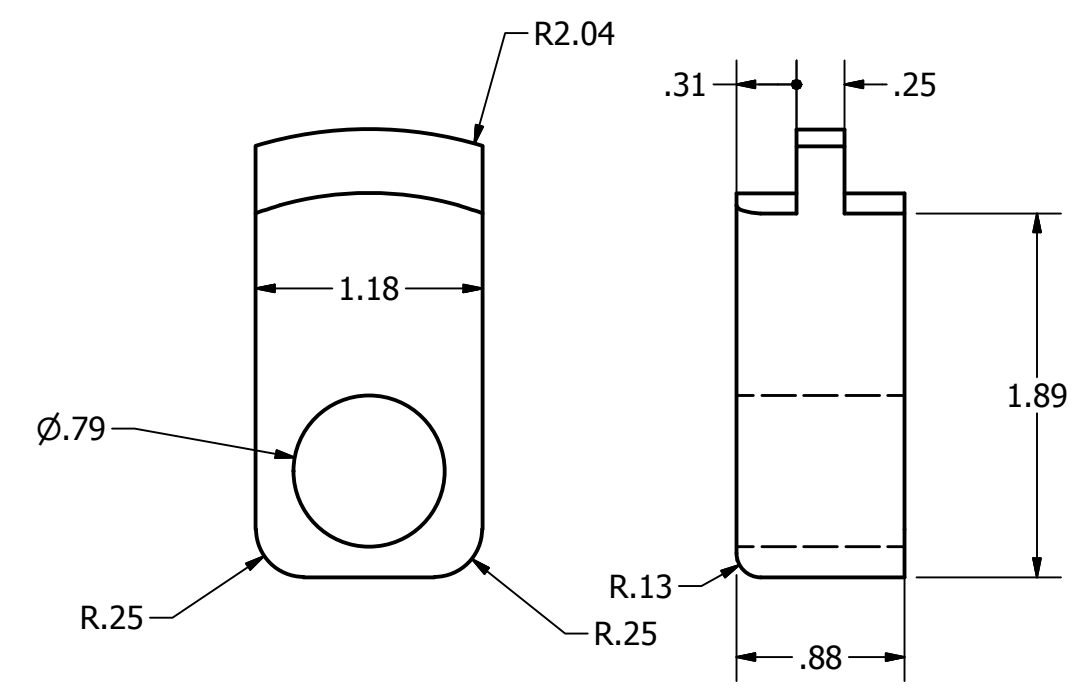

SIZE D	CAGE CODE 21356	DWG NO ?	REV
SCALE 2	ORG OZ4	FMT FOZMAY04	SHEET 6 OF 9

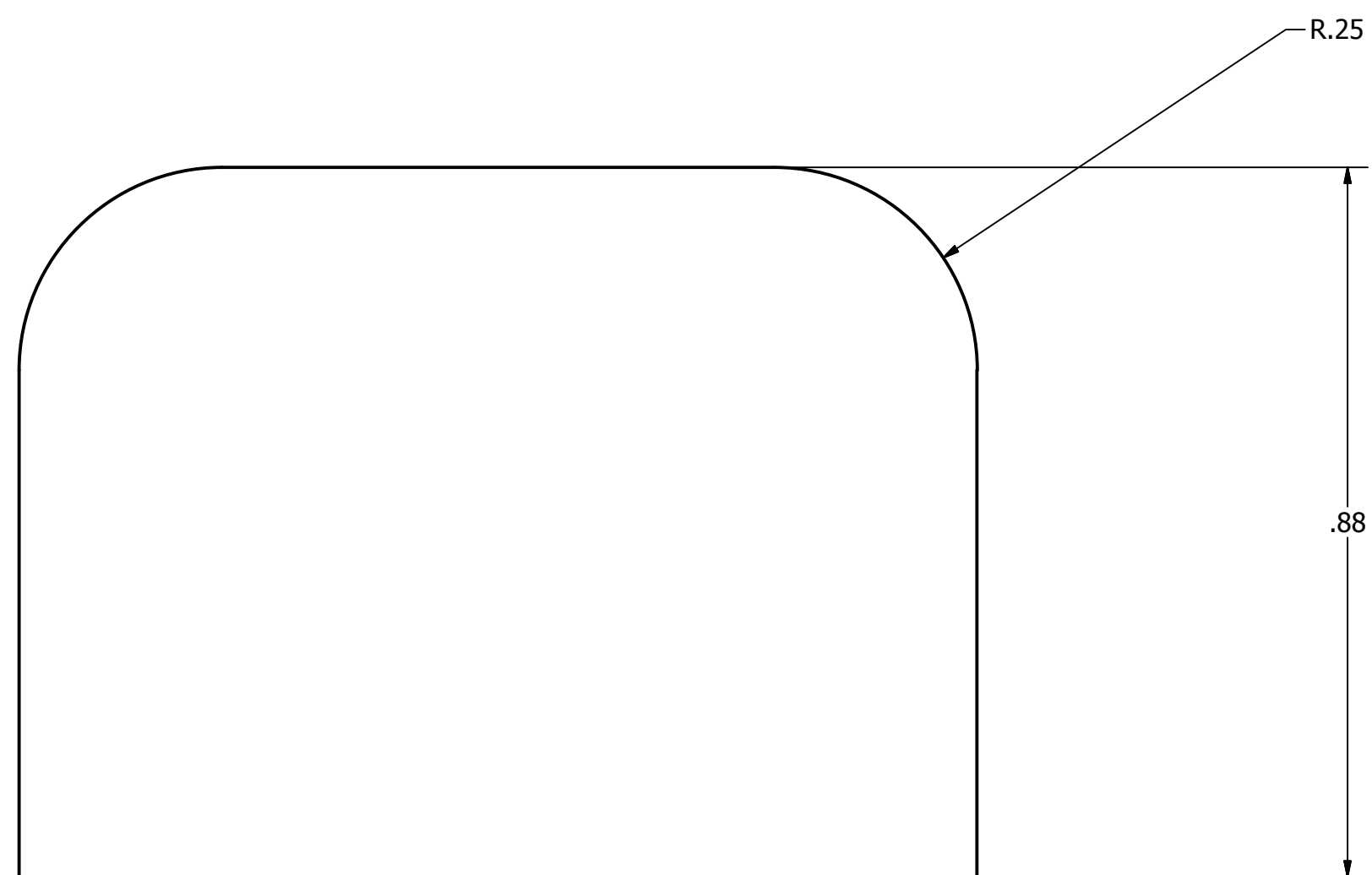
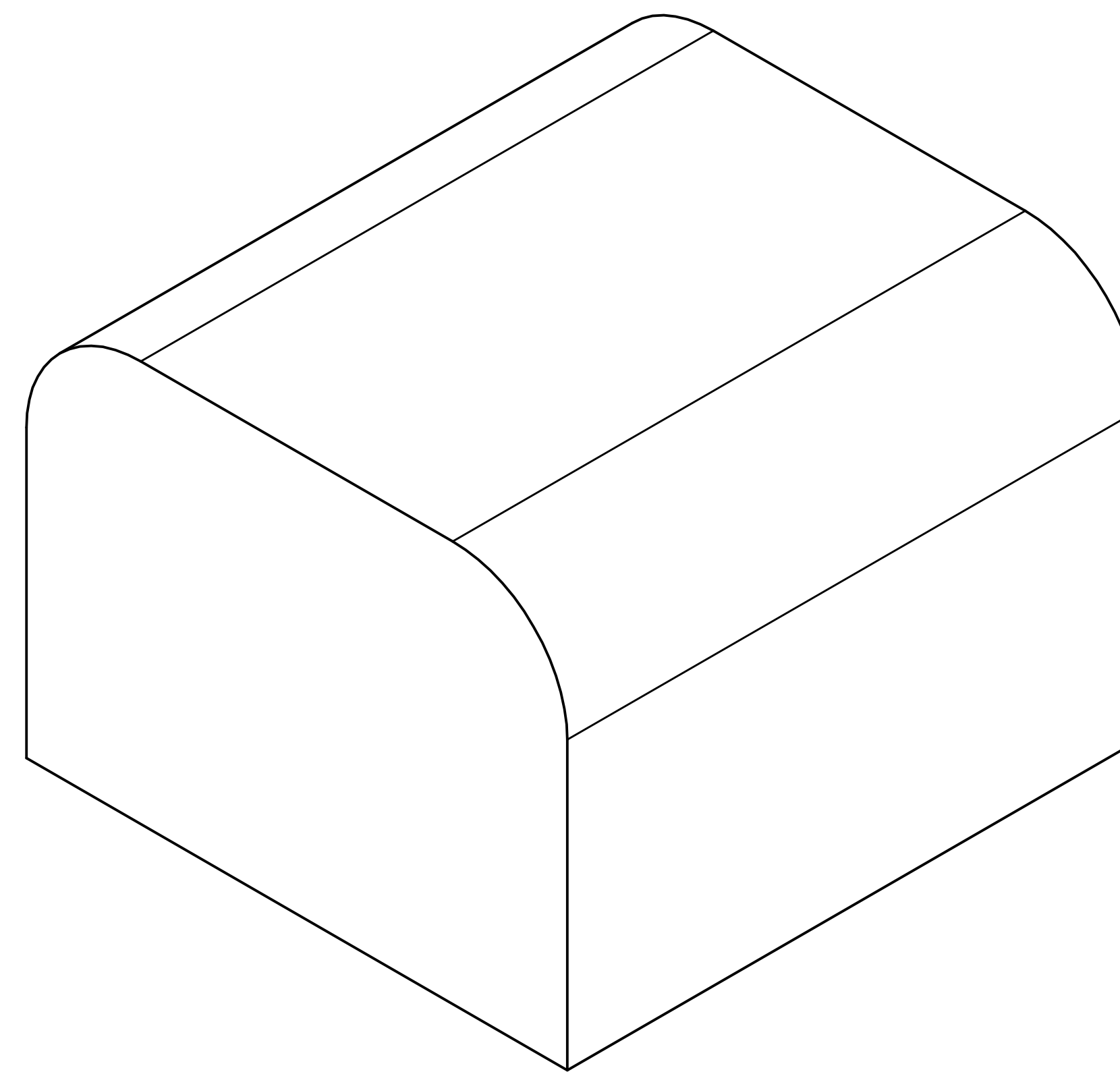
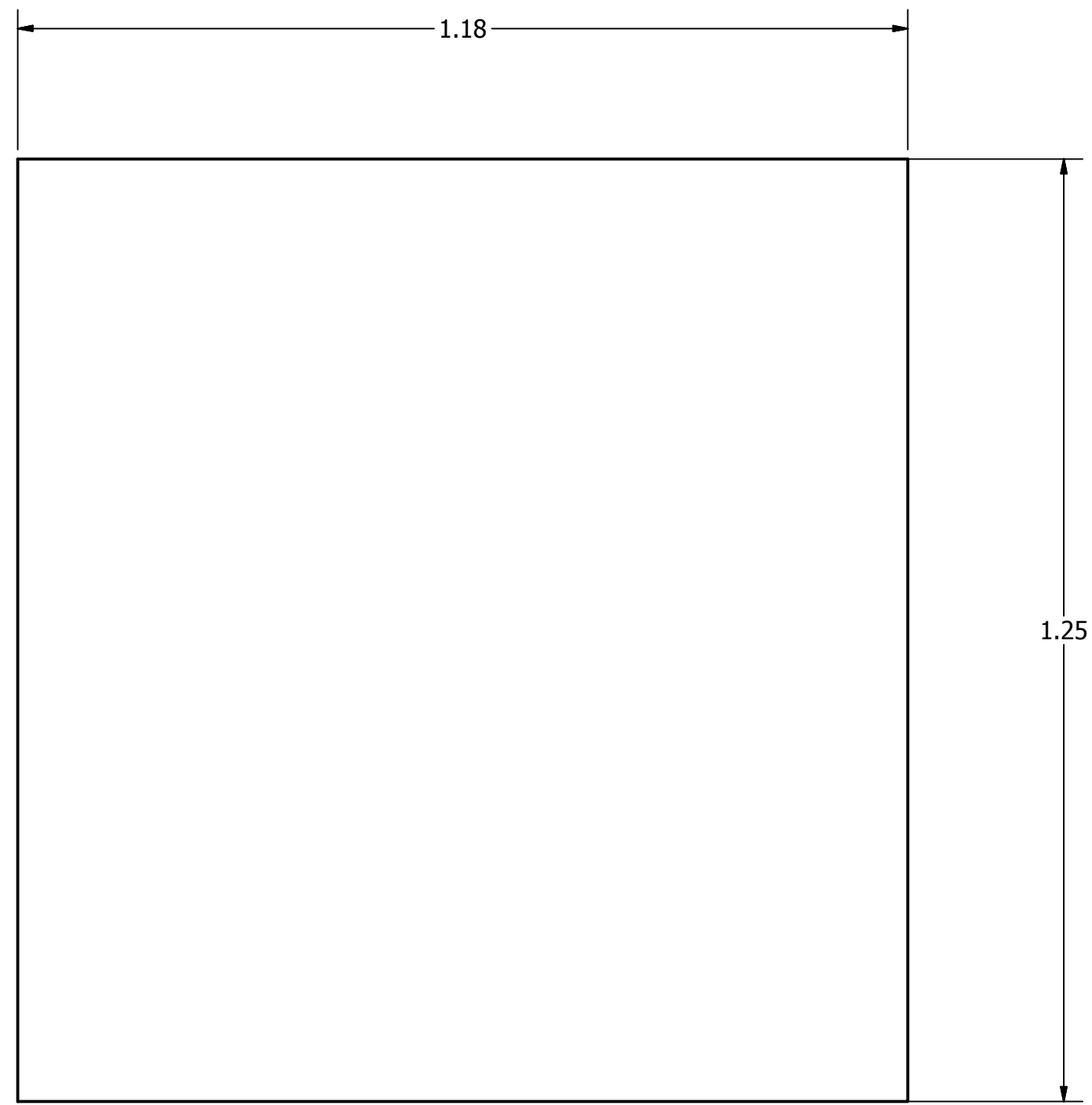

SIZE D	CAGE CODE 21356	DWG NO ?	REV
SCALE 2	ORG OZ4	FMT FOZMAY04	SHEET 7 OF 9

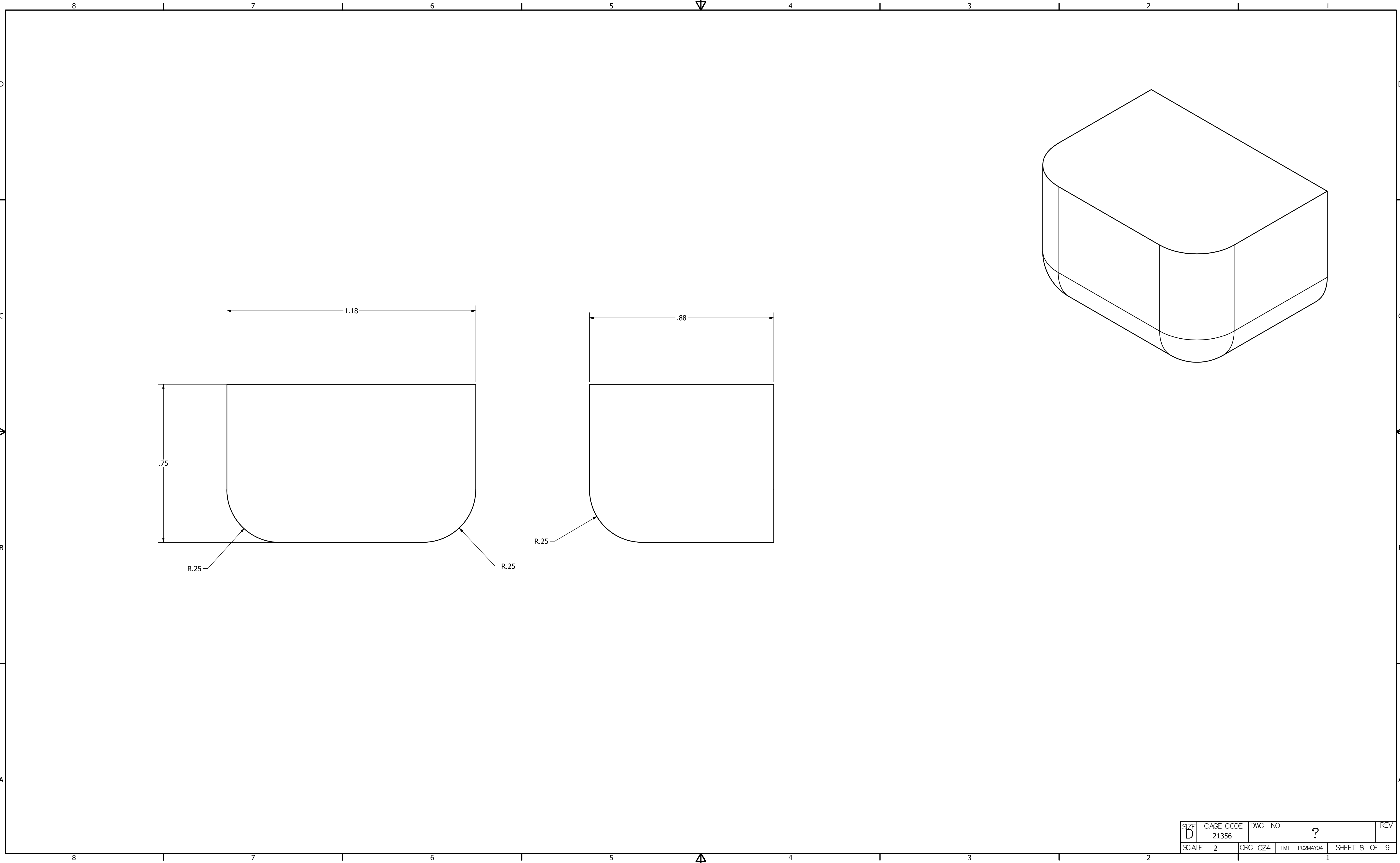

SIZE D	CAGE CODE 21356	DWG NO ?	REV
SCALE 2	ORG OZ4	FMT F02MAY04	SHEET 8 OF 9

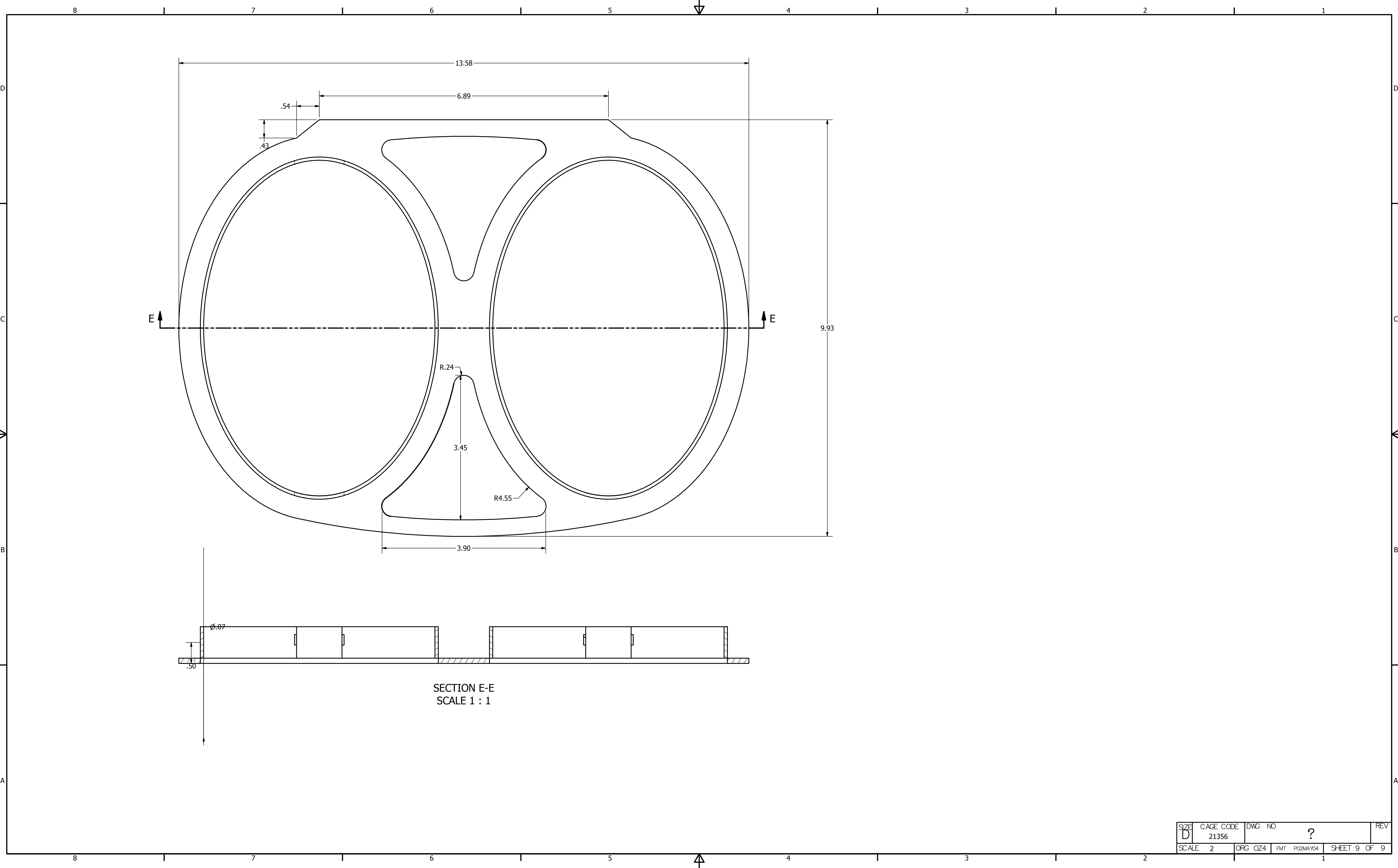

SECTION E-E
SCALE 1 : 1

SIZE D	CAGE CODE 21356	DWG NO ?	REV
SCALE 2	ORG OZ4	FMT P02MAY04	SHEET 9 OF 9