

# VR Simulated Gravity

Develop a virtual reality simulator that would demonstrate some of the difficulties with a centrifuge spaceship.

Glenn Johnson NASA HUNCH

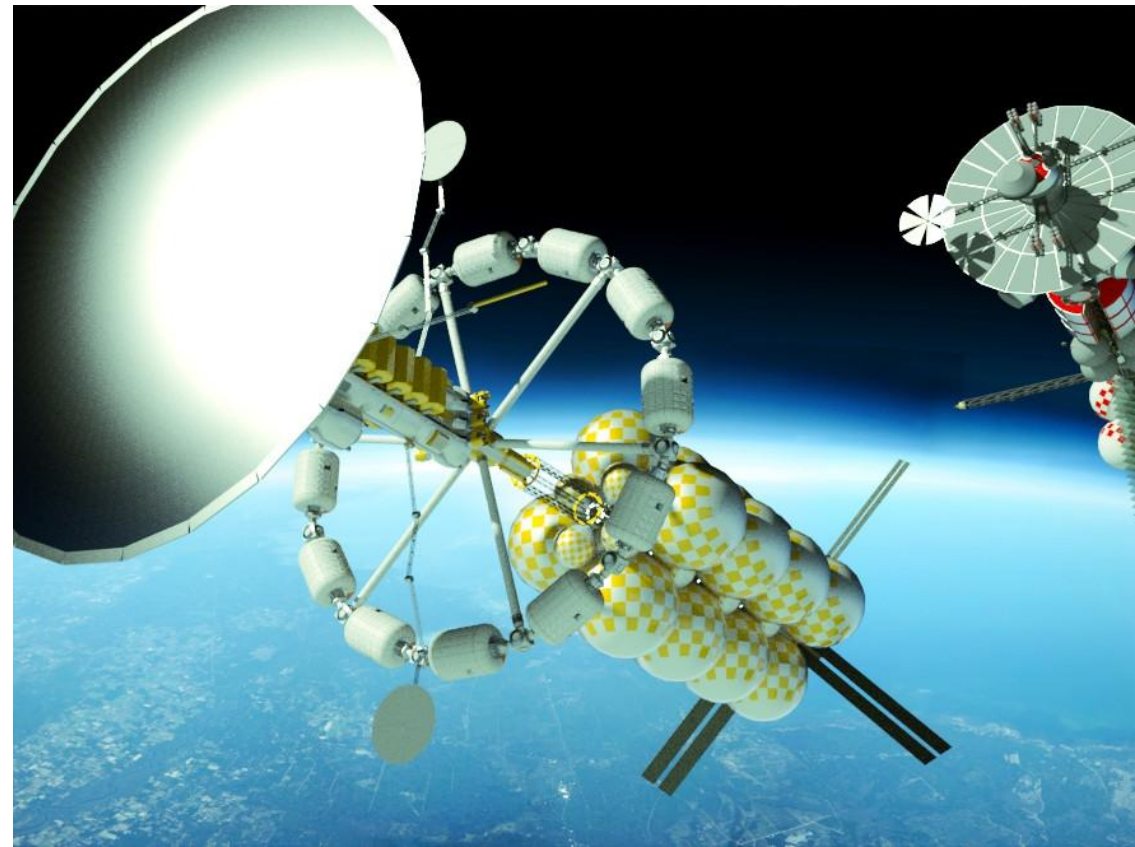
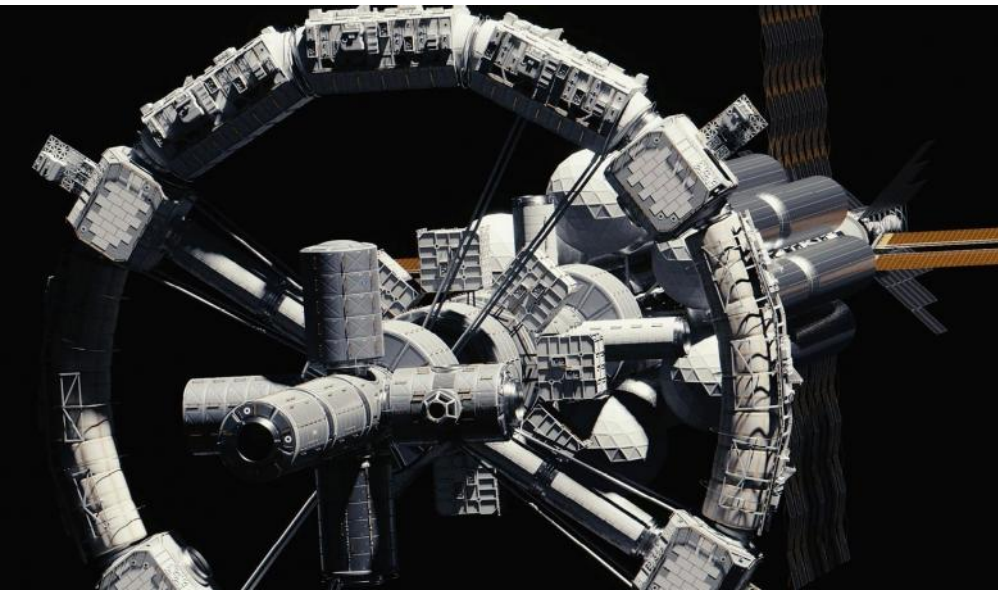

# Requirements

## Problem:

In many science fiction movies, the space craft rotate to make a simulated gravity for part of the ship. The problem is that there are differences between a large spinning wheel and a gravitational body like Earth. Simulated gravity has been talked about for decades but has never been tried. Before we send people on long distance trips in a spinning can, we need to build one for an Earth orbit where problems can be found and then solved. Before NASA spends the money on a rotating module in space, we should test out some of the ideas before we build it. **This is a great use for Virtual Reality. It would be best if the team has experience using Unity or Unreal Engine or another game building software.**

## Objective:

Develop a Virtual Reality simulation that will help train astronauts and engineers of the difficulties in a rotating space craft 15m in diameter and rotating at a sufficient velocity to produce 1 g.

- This simulator should include the following objects:
  - A toroidal module 15m in diameter and 3m wide that connects with a central core module
  - Two ladders leading from the central core down to the outer ring
  - Include least two people capable of running and doing work outs
  - 3 baseballs for juggling and throwing to another person
  - A hose for watering the plants
  - Several 'pillows' for growing plants in(you may choose the type of plants)(can't use rigid pots in space)
  - Bar bells and a set of weights
  - A flying drone
  - A shower
  - 3 Pendulum clocks on the wall at different heights (these will keep time differently if they are identical clocks)
  - A table to place the baseballs on.
- Although the final product will need to utilize a head set and hand controllers that will allow the user to walk around and interact in the virtual world, the initial version only needs to demonstrate the software.

The pictures on this page are not intended to be innovative but only to give everyone something simple to design around. We are trying to tease out the difficulties related to the physics and engineering of the first experimental rotating space craft. We are not trying to develop the next science fiction movie's vehicle but some of the lessons learned from this could be beneficial to science fiction as well.

Because no one has ever built one of these, we are really using a little bit of the science fiction to help us begin but hopefully this is based as much as possible in available technology. The intention with the chosen dimensions was to scale it to a size that may be similar to what could be launched with the current fleet of rockets and fairings. I expect this will probably be an inflated module that will launch relatively small and inflated to the described size over several hours. The inflation tanks would be in the rigid core module and they would look similar to scuba tanks (blue circles) but they would be removed and discarded once the crew starts using the module. Other modules would attach to either side of the core module by way of a static docking mechanism and standard hatches. Many science fiction movies show a static central core and a rotating ring. I feel it is unlikely that NASA would try to have a rotating slip ring where an air leak might be more likely. A rotating ring would also imply that the central core would have to rotate in the opposite direction. By having stationary connections between the ring and the central core means that the whole space craft will rotate and that the central core walls would only have a very small simulated gravity because it is so close to the center of rotation. The very center of the core module would have no simulated gravity.

How do you set up your gravity field in the gaming software—this can be tricky?

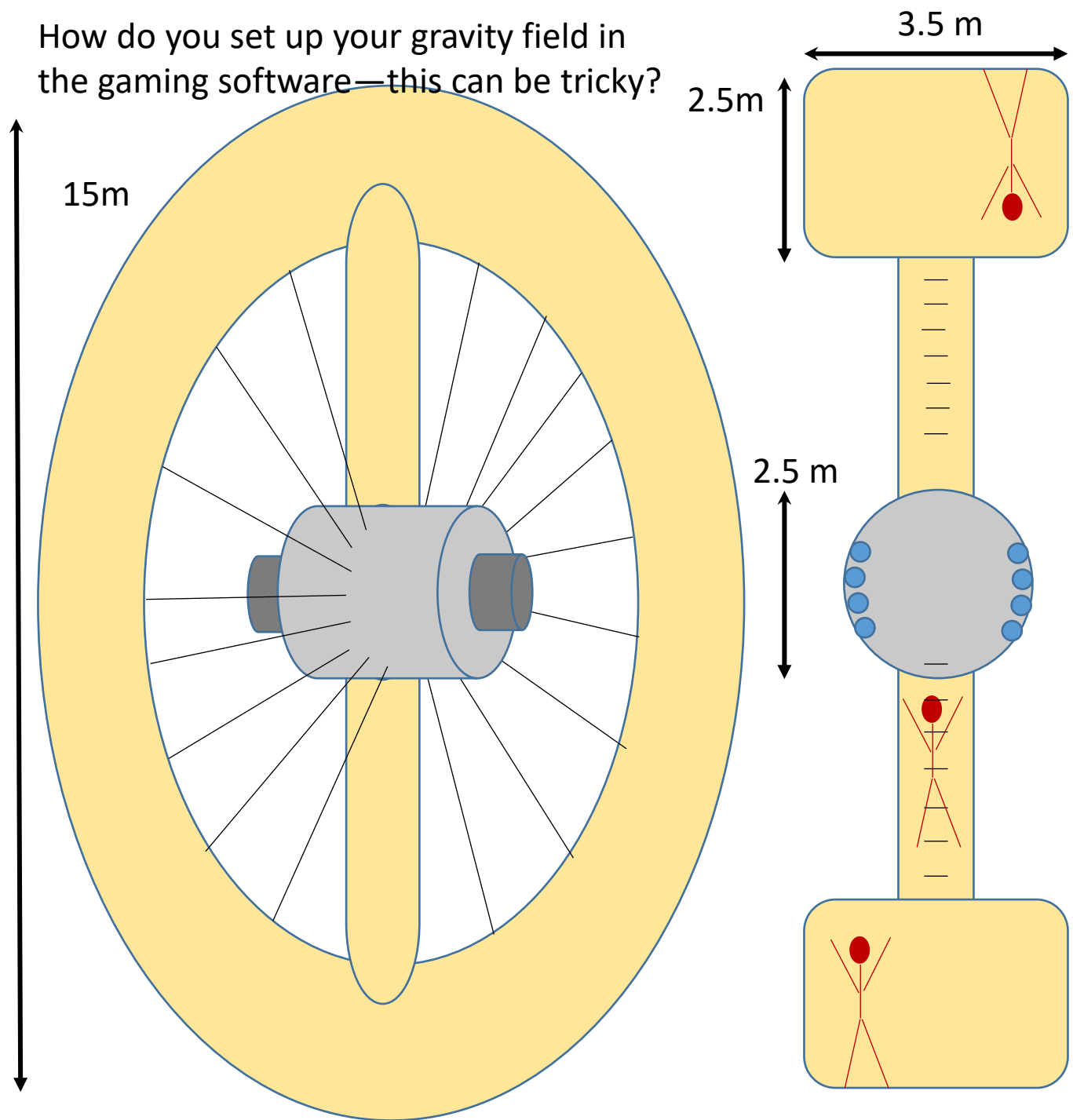

# Problem:

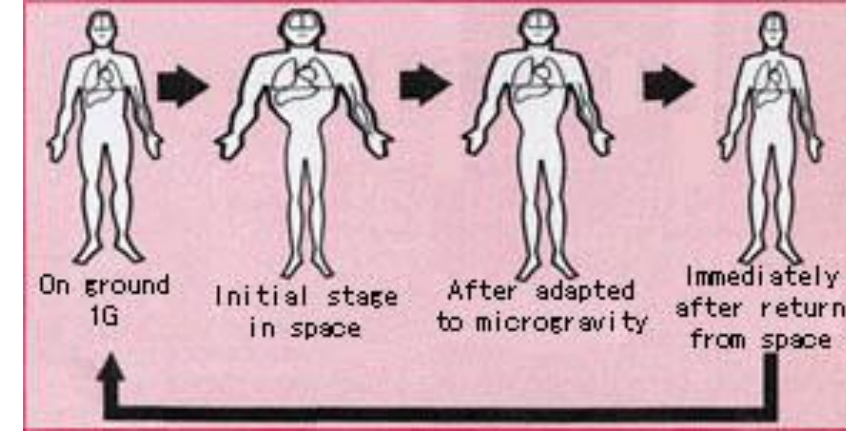
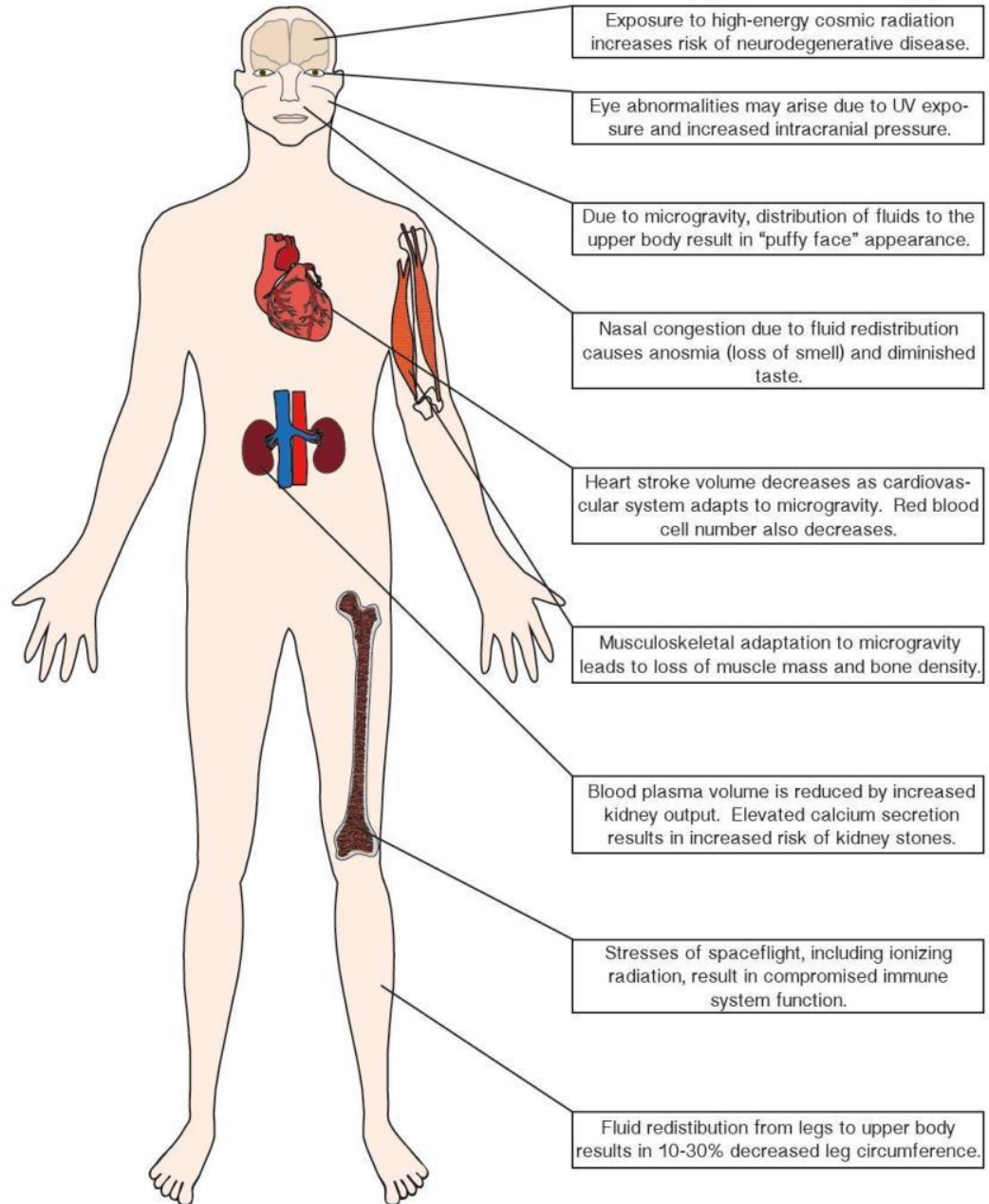

When astronauts live on the Space Station for several months at a time, even though they exercise every day, they often have difficulties when they return home. Many astronauts have difficulty with their balance, trouble walking, health issues like problems with their digestive systems, changing prescriptions for their eyes, bloating of their ankles, throwing up and more. They are usually watched for the first several days after they return to Earth. Traveling to Mars or some other far off destination is going to be problematic when they land on Mars without any assistance to acclimating to the new gravity. One of the suggested answers is to simulate gravity on the way to Mars by rotating the ship so the crew can minimize the effects of zero-g.

# Part of the ship rotates with another part stationary

- In many science fiction movies, the space craft rotate to make a simulated gravity for part of the ship. The problem is that there are differences between a large spinning wheel and a gravitational body like Earth.
  - Gravity will change as you go from the center of the ship to the outside of the spinning portion of the ship.
  - If I run in one direction my simulated weight will increase, if I run the other direction it will decrease.
  - If I throw a ball in any direction on earth, the ball goes in a straight direction from my observation. If instead I throw the ball in one direction on a spinning structure it will look like it is curving. If I throw it the opposite direction it will look like it is curving the other direction. This is due to the Coriolis effect.
- One of the difficulties with a portion of the ship rotating design but the central core is 'stationary', is that there has to be a rotating seal for that to work which could be problematic—we don't want to lose air and we don't want to damage the seal when we turn the engines on. There isn't any friction in space for the outside of the ship but there is friction in the bearings that allow it to rotate but not lose air. The central core has to rotate the opposite direction—friction in the bearings and Newton's 3<sup>rd</sup> law with a motor that keeps it rotating. This means that some of the doors and passageways would open and close as it rotates---**don't get caught in a doorway.**
- There would need to be slip rings for transferring electrical power into the rotating component. Hoses that allow rotation for transferring water.



# Whole ship rotates

It would be much more realistic and easier to model to have the whole ship rotate and be a solid piece so it doesn't leak at the seal and there would be no need for a motor to keep it rotating. The hoses and cables could still be solid connections. The hatchways would always be open and easy to close if there is an air leak. This would mean that the ship would have some simulated gravity everywhere but it would decrease as you get closer to the center of the ship and stronger as you get further away from the center. Even if NASA wants the more complicated system, **this simpler design is what I would like your simulation to be so that we are starting with something easy.**

Before we build a big space station or a spaceship for traveling to Mars that rotates like this, we will need to build a smaller one (affordable) and can demonstrate the technology. We need to see what kind of problems we encounter with a rotating space craft. There will be problems with equipment and people adapting to this new environment. It will probably have to be separate from the International Space Station which is a platform for doing experiments in zero-g (not simulated gravity).

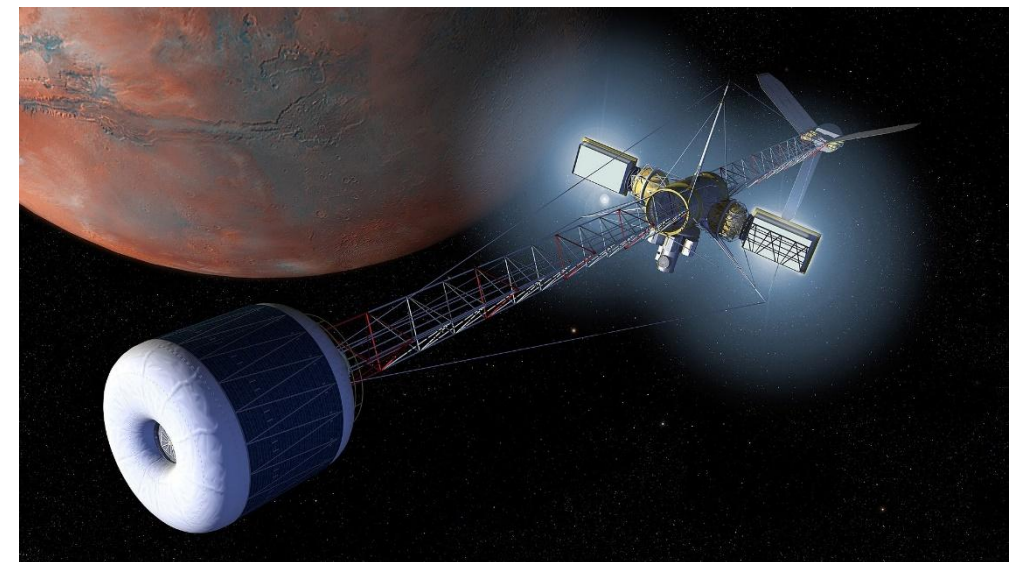
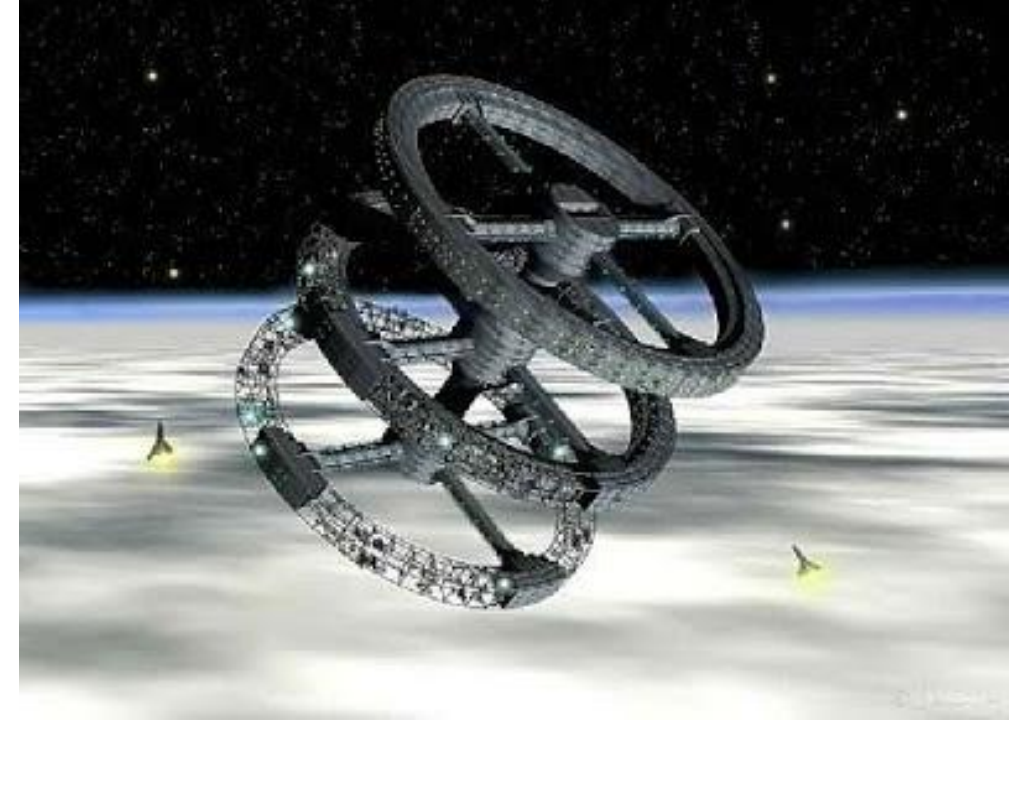

# Simulated gravity in science fiction movies

- 2001 a space odyssey—Space Station.

<https://www.youtube.com/watch?v=q3oHmVhviO8>

- 2001 a space odyssey—Discovery space ship that is nearly a mile long and the carousel in the middle that allows them to simulate gravity. The interior dimension is similar to what we are trying to do with this simulator.

<https://www.youtube.com/watch?v=1wJQ5UrAsIY>

- The Martian—the Hermes--vehicle that goes to and from Mars is very big and has a rotating portion of the ship and a stationary portion. Not what we are trying to do but still some interesting ideas.

<https://www.youtube.com/watch?v=y-u2w17Vdrw>

# Some resources to help understand Centrifugal vs. Centripetal force

- When I was a kid, I lived on a farm in Idaho. We had chickens, cows, goats and it was my job to collect the eggs and water the animals. Any time I had a bucket I was swinging it around to see how fast I could spin it over my head and keep the contents in the bucket—water, oats for the cows or eggs I had collected. I would also see how slow I could swing it and stuff not fall out—that was more challenging and would either get me wet or in trouble for dropping eggs.
- Imagine being on a merry go round that is spinning quickly. Lay down so your feet are at the outer edge and your head near the center. Your feet are feeling more simulated gravity field than your head. Now allow yourself to slide toward the outside of the merry go round, your head will go from a distance far from the edge to closer to the edge. Your head will be going from a small simulated gravity field to a higher simulated gravity field. If you then try to sit up, you will feel a swirling sensation because you have Earth's gravity pulling you down and the centrifugal force from merry go round pulling you toward the outer edge. This will be confusing to the balancing mechanisms in your ears that help you know your orientation.

- Mr. Wizard—centrifugal force in a roller-coaster.

<https://www.youtube.com/watch?v=gRVIWWJwzfy>

- Definition and description of Centripetal and Centrifugal forces.

<https://www.youtube.com/watch?v=9s1IRJbL2Co>

<https://www.youtube.com/watch?v=rqyNdYc4UBY>

Please look up more for you to gain understanding and to see things I'm missing.

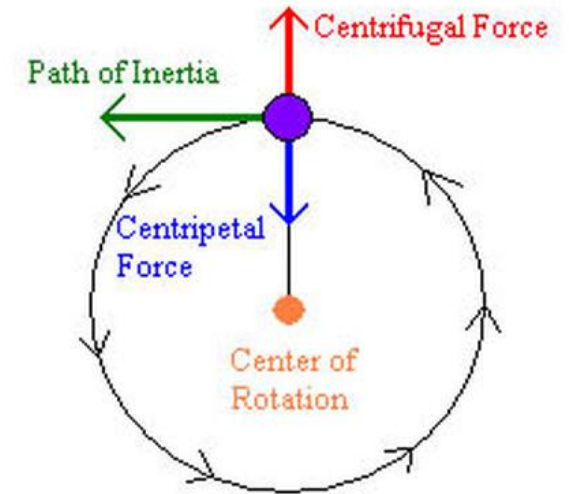

## Centripetal Force Equation

Combining these two equations . . .

$$F_c = ma_c \text{ and } a_c = \frac{v^2}{r}$$

you get:

$$F_c = \frac{mv^2}{r}$$

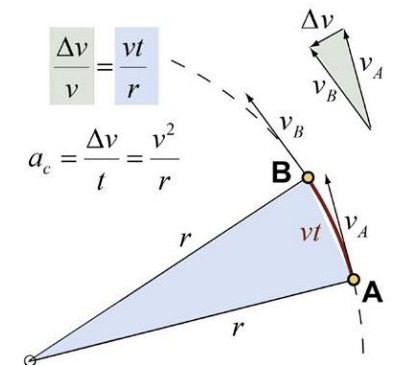

# Videos that help explain the difficulties

- <https://www.youtube.com/watch?v=wYDJ0vxg1IU>
- <https://www.youtube.com/watch?v=b3D7QIMVa5s>
- <https://www.youtube.com/watch?v=C41gKfiihiM&t=10s>

# Coriolis Effect

- The Coriolis Effect is what explains the big pendulums that you might have seen at museum that are knocking over pegs on the floor. Imagine placing a pendulum that can swing in any direction on the **North pole**. If you start swinging the pendulum in a particular direction, it will continue to swing in the same plane because of Newton's law that an object in motion will tend to remain in motion unless another force acts upon it. If we place 360 dominos around the pendulum, the pendulum will continue to swing in the same direction it started swinging. The pendulum will knock all the dominos down as the Earth rotates under the swinging pendulum. If this pendulum were stopped and moved south, once started at the new location, the pendulum would knock down fewer dominos as the location moved toward the equator.
- Imagine standing on the North pole and sending a rocket straight south. If you are a person watching from outside the Earth, this rocket would travel straight south but from the perspective of the person standing on the ground south of the launch point, the rocket is curving west. This difference in perspective is because the Earth is rotating but the rocket is no longer rotating with the Earth. This is most obvious when sitting on the north or south poles but it happens to different amounts as you change location on the Earth and direction of where you aim.
- This is a problem the military has when firing rockets or firing big guns and have to use tables to correct their aim depending where they are located and what direction they are firing the weapon. The British Navy had difficulties with this in the 1980s when they were at war with Argentina over the Falkland Islands. Their ballistic tables were set up for warfare in the Northern hemisphere but they were fighting in the southern hemisphere and their Coriolis corrections were going the wrong way and they were missing the enemy's ships until they could figure out the problem.
- People who shoot high powered rifles long distances also have to correct for the Coriolis effect.
- This is also part of the reason for large storms rotating-- like hurricanes. I'll let you look it up.
- It is a myth that water in a toilet flushes in the opposite direction in the southern hemisphere from the northern hemisphere. Differences in the direction of water swirling in a toilet is related to how the water jets are directed into the bowl. The Coriolis effect requires much longer distances than the few inches of a toilet bowl.

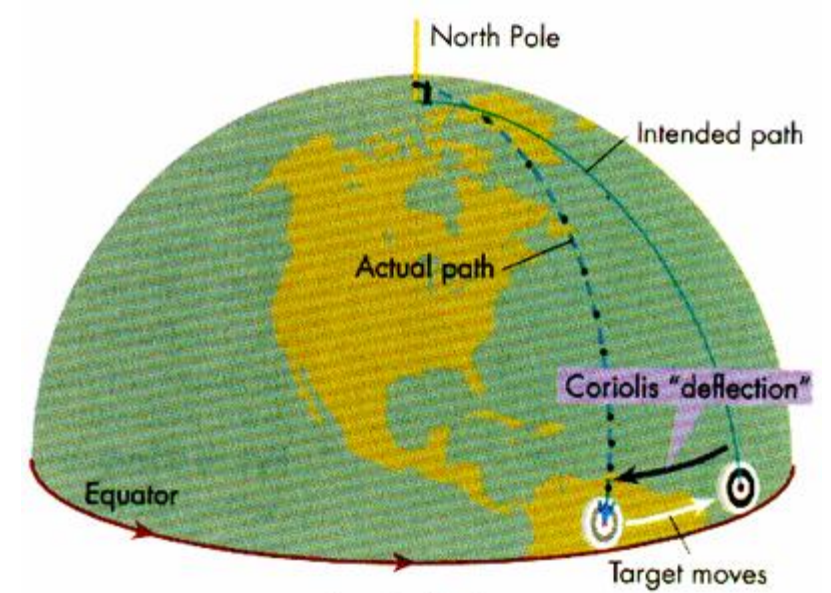

Rotating Earth

Due to the earth's rotation

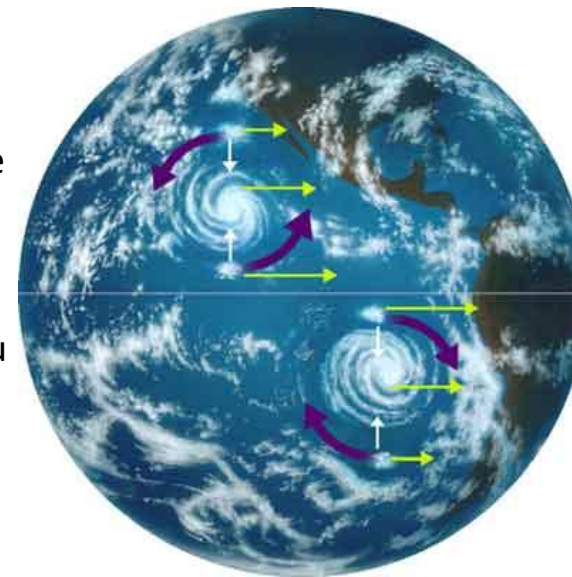
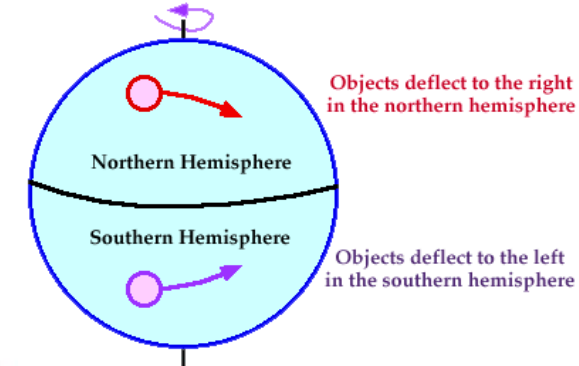

# Conservation of Angular Momentum

What happens when astronauts shift around in the rotating space craft?

- Imagine if they start rotating the space craft when all the crew members are in the central core. They spin it up so that it simulates 1 g when standing on the floor of the toroid. Let's assume there are 6 astronauts that will be using this space craft to go to Mars. Let's also assume they have an average mass of 70kg per astronaut, so they have a total mass of 420kg. If they all decide to go to their sleeping quarters in the toroid, they are shifting the mass from the center of the rotation outward. This is like an ice skater moving their arms out while in a spin--the spaceship will decrease its rotation proportional to the amount of mass. Then as they get up in the morning and go work in the central core, the space station will rotate faster just like the ice skater who pulls their arms in while spinning.
- I'm not sure how much this will affect the space craft since the mass of the people will be fairly small compared to the space craft but it may be an important factor for us to consider at some point in the program. The bigger factor may be shifting supplies from the central core to the toroid-- this would also slow the rotation. It is possible this could affect the water pressure in the system that is in tanks or flowing through the piping either in the toroid or in the central core.

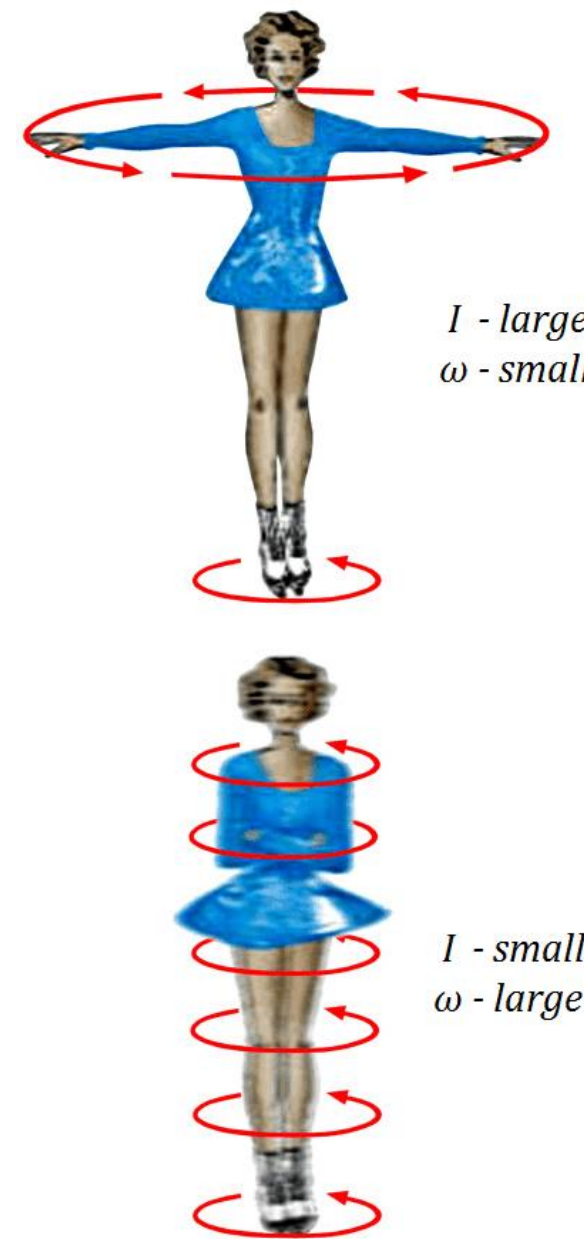

$$\begin{array}{rclcl} \text{Angular} & = & \text{Moment of} & \times & \text{Angular} \\ \text{Momentum} & & \text{Inertia} & & \text{Velocity} \\ L & = & I & \times & \omega \end{array}$$

# Things to build into the program

Before we build a big space station or a space ship that rotates like this, we will need to build a smaller one (affordable) and can demonstrate the technology. We need to see what kind of problems we encounter with a rotating space craft. There will be problems with equipment and people adapting to this new environment.

- It may be valuable to start by building the vehicle in your CAD program and then import the toroidal vehicle into Unity or Unreal Engine
- Force gages—develop some kind of visual gages for each person that will indicate how much force they are experiencing at different locations of their body. Ex— one gage at their head, one at their belly button and one at their feet. These might show different forces depending on their distance from the core of the vehicle or their distance from the outer ring.
- Make it so the rotation can be changed + or - .5 g
- Pendulums on the wall showing how they swing differently as you go up the wall and the direction they are swinging relative to the rotation.
- Lifting weights from floor to above head—how much will the weight change from the floor to above their head—2m difference?
- Flying drone?—if it is not touching the sides, how will it hold its position so it can do a task?
- Watch a ball being thrown---show the pathway with dotted lines
  - In the direction of rotation
  - Opposite the direction of rotation
  - From one side of the hallway to the other side of the hallway—both directions.
- Running in different directions—how much of a difference in work out would a person get from going with the rotation or against the rotation?
- Watering plants with a hose to see how the parabola is different.
  - The parabola will be shortened when the water is squirting into the direction of the rotation
  - The parabola will be lengthened when the water is squirting with the direction of the rotation
  - The parabola will curve away from the direction of the rotation when squirting to the side.

# The bigger problem

- Although the majority of time we might expect it to be spinning to simulate gravity, there will be times when it can't spin... like maybe when another ship is docking or when doing specialized communications with Earth from Mars, when doing a space walk. That means the equipment will need to be both operational for zero-g and when in 1 g. There may be times when some equipment is not operational.
- The much bigger picture is that engineers will need to plan how to build a space craft that needs to rotate.
  - How strong does the structure have to be to handle the rotation and people running in it?
  - This is a lot of rotational inertia, how will it affect the space craft as it orbits around the Earth?
  - The whole spaceship is acting as its own gyroscope. When will this be a problem?
  - How will a spinning space craft affect the power it can generate with solar panels?
  - How will the fluids flow in pipes and hoses with varying amounts of simulated gravity?
  - Does it have to be simulated 1 g or could it simulate some fraction of gravity?
  - Will going into and out of simulated gravity cause more space sickness?
  - Do you place the toilet in the center core of the ship or in the toroid part of the ship?
  - Should that toilet be a zero-g toilet or a gravity toilet? Or both... and how does that work?
  - Would it be better to have astronauts run around the toroid and spread out the bouncing to the whole shape or should there be a treadmill and have all the bouncing in one location?

None of these things do I think we can or should try to answer at this time. However, the VR simulation that you develop will help engineers understand and visualize what their problems might be and how to develop solutions to those problems.

# Pointers to help you fill out the space

- After it is on orbit and inflated to its size, it will be mostly empty and have to be outfitted with most of its hardware. This will be a very large volume and will probably be used for many of the daily activities and the general habitat. Remember that there will be times that they will have to stop the rotation for some portion of the mission. That means that everything that is normally held on the 'floor' by simulated gravity will start floating around—we don't want that to happen. It is also possible that there are long portions of a mission that the craft should not rotate (docking maneuvers, orbital maneuvering, extended zero-g experiments, moving of supplies and equipment, and many things I don't know about). This means that all of the habitat equipment may also have to be at least partially functional in zero-g. The following descriptions are things your team can add to make it feel more life like but **the most important components of this projects are the exploring the Coriolis effects and the changes in the centrifugal forces as we move about the whole space station.**
- Around the toroid will be six small sleeping quarters , a workout area, toilet room (2), galley area (table, chairs, rehydration station, food warmer), emergency medical area with table, LED lighting, hoses carrying air flow. The separations for different areas and rooms may only be some kind of cloth partition. This would be lighter weight for launch considerations and may allow the partitions to be in place while the module inflates.
- Imagine the inside of a sleeper car for a train going cross country. The rooms in one train car are on one side and the walkway is on the other. But in the next train car it is reversed. In an effort to keep the mass of the rotating module distributed more evenly and keep the rotation even, it would be good to alternate the side of the rooms and the walkway similar to the cross-country train. So in one area a sleeping quarters is on the left side of the toroid and the walkway is on the right but in the next segment the sleeping quarters is on the right and the walkway is on the left.
- Sleeping quarters will need a bed and some drawers for clothing. A computer and a simple desk with a simple chair. Maybe a small sink for personal cleaning.
- All of these items are really just suggestions. If you are looking through images of other toroidal space craft on the internet and see something that looks helpful, you may use it if it adds more life to your virtual reality space.

# Tips for the video presentation

- Start your view from the outside of the rotating space craft so the reviewer can see the bigger idea of the space craft. Take about 20 sec. to move into the central core module, look around the central module. Travel down one of the radial tubes showing the ladder. Is there a way to show that the simulated gravity is increasing?
- Walk around the inside of the toroid and show the space and the furnishings mentioned earlier in the presentation.
- If you were to move supplies (water, food, batteries,...)from the central core to the toroid ring, what should you expect to happen to the rotation rate? What if the supplies are all moved to the same area of the toroid, how would it affect the rotation? Is this visible from the outside of the vehicle? From the inside of the vehicle?
- You can have some people building the module, pendulums, tables, chairs, bags, computers... in Solid Works or Inventor or Fusion and then import those models into the Unity or Unreal Engine or whatever you choose. You can also find equipment that other people have built and import that into your rotating module to help get it outfitted. Be careful that anything you import matches your need in the new type of space craft.

# Kerbal Space Program

Here are a couple of images I found that look very similar to what I have been trying to describe. The top one is made by a user called Porkjet. I understand it was some teaser artwork. I like several aspects of the design including the central core, visible hatch, the cables, the two hallways leading to the ring. I think the outer shape would be smoother but I'm not an expert on flexible space craft. The interior shot was done by someone else and is a good visual for the internal space of the ring. My suggestion is for a wider and more rectangular ring but here you can see the ladder leading up to the core and some of the supplies and personal space in the ring. I think these people are thinking in a good direction for an early design for a rotating module.

There may be some value in putting arrows on the floor to designate what direction the vehicle is rotating since we expect that running or walking in one direction will be different than running in the other direction.

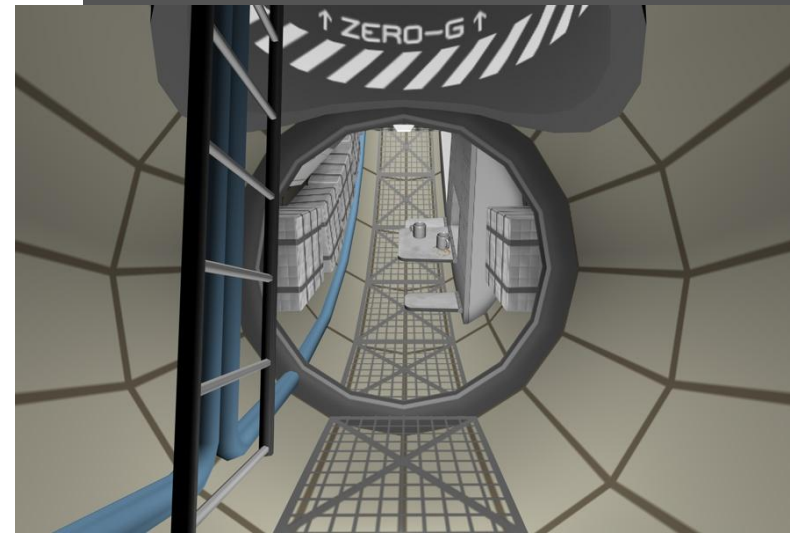
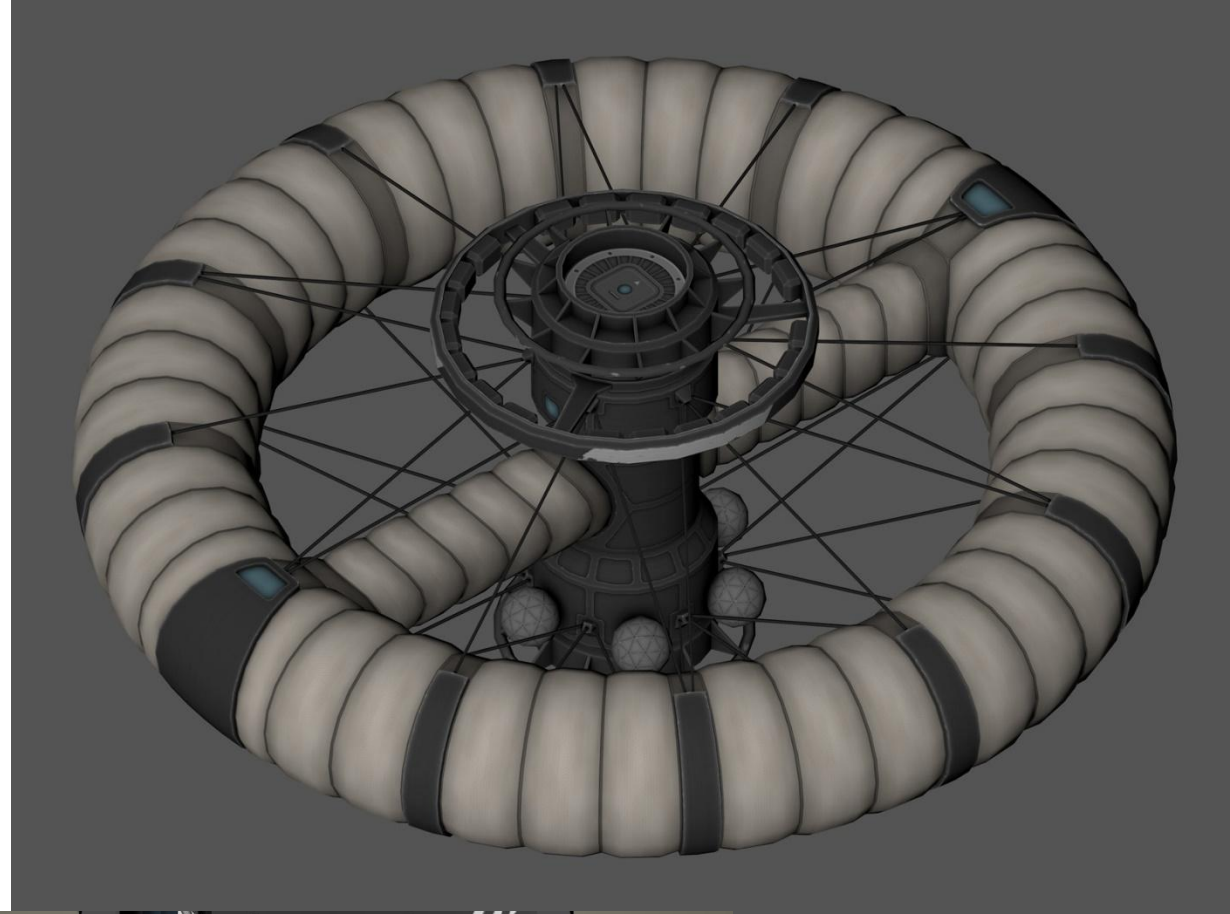

# Requirements for VR Simulated Gravity Module

1. Show a video of an astronaut floating on the outside of your rotating module to show the exterior of the module and then move into the central core of the module
2. Give a tour of the inside of the central core and any internal equipment you have installed (tanks for inflation, lights, some handrails, Storage bags, hatches,...)
3. Go down one of the radial arms (ladder, lighting, emergency equipment on the walls)
4. Show how gravity increases as you get further from the central core.
5. Show astronaut walking on the floor of toroid (floor should have indicators for direction of rotation) to give a tour of the toroid—internal lighting, private bedrooms(four), table in experiment area, Galley area (microwave, water dispenser, boxes of food pouches), hygiene facility (shower stall, toilet room, sink), group area for recreation or experimentation, several small windows (some pointing toward the central core, some looking elsewhere).
6. Water plants to show how the water path will change directions due to Coriolis effect
7. Show internal dimensions of the toroid.
8. 3 pendulums at different heights on the wall that show the different levels of gravity
9. Can you show the mass of the spinning module?
10. Can you show how moving the supplies from the central core will change the rotation if moved to the toroid? (this would be something to watch from the outside of the module)